

# User Guide



6.5" Car Stereo Speakers

**NS-S6501**



# Insignia NS-S6501 6.5" Car Stereo Speakers

## Features

### Included:

- 6.5" speakers (2)
- Speaker wire mounting leads
- Mounting screws (8)
- Mounting clips (8)

### Dimensions

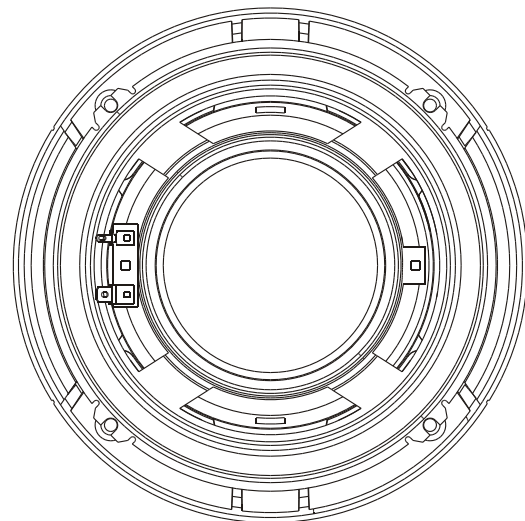
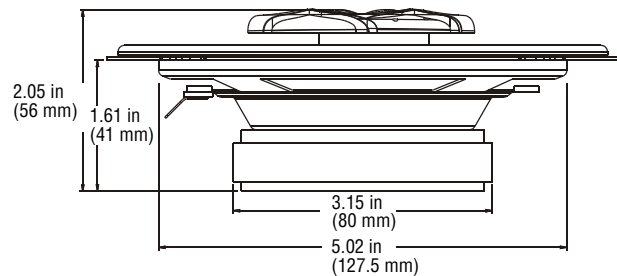
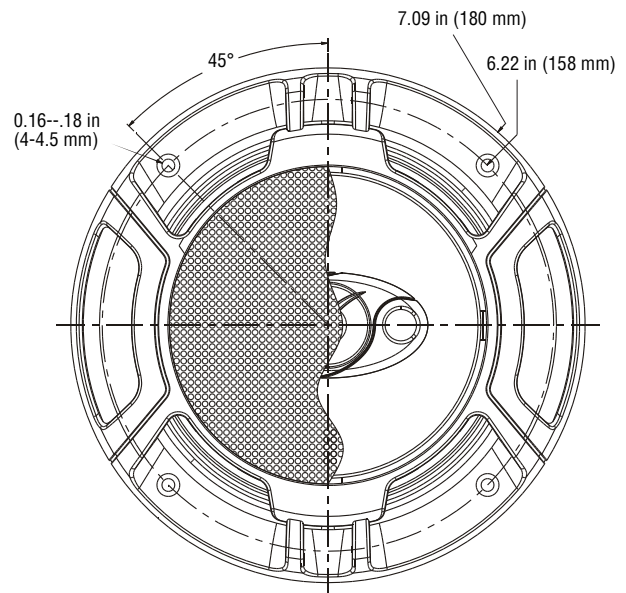

## Introduction

Congratulations on your purchase of a high-quality Insignia product. Your NS-S6501 Car Stereo Speakers represent the state of the art in car speaker design, and are designed for reliable and trouble-free performance.

## Safety information

- This *User Guide* contains important instructions for your safety. Make sure that you refer to it.
- Do not install the speakers where they may be subjected to excessive heat, moisture, or dust, or where they will be kicked repeatedly, brushed, or bumped.
- To prevent a short circuit, never leave any metal objects, such as coins or metal tools, inside the acoustic system.
- Make absolutely sure that the positive (+) and negative (-) terminals of the speakers are connected to the correct outputs from the music source.
- Never run the wiring on the outside of, or under, the vehicle, where it can be damaged by road hazards or moving parts of the vehicle. Use existing wire channels, sills, panels, and moulding strips inside the vehicle to hide the wiring for safety and a neat appearance.
- When your speakers are connected, turn on the various components and slowly turn up the volume. Make sure that you check and double-check all connections to insure correct installation and use.
- Do not overload the speakers beyond their nominal power handling capacity.
- Keep recorded tapes, watches, and personal credit cards using magnetic coding away from the speakers to protect them from damage caused by the magnets in the speakers.
- If you cannot find an appropriate mounting location, consult your car or sound system dealer before mounting.

### Warning

- Before mounting the speakers and connecting the wires, make sure that the negative battery cable is disconnected from the battery. Failure to do this may cause a short circuit or fire.
- Use extreme caution when working near the gas tank, gas lines, or hydraulic lines with electrical wiring.

## Troubleshooting

Always test the speakers and speaker wires. Make sure that the speakers are connected with the correct polarity (positive (+) amplifier output to positive (+) speaker terminal and negative (-) amplifier output to negative (-) speaker terminal).

## Specifications

Frequency	80-20 kHz
Sensitivity	88dB/W/M
Peak power	100 W
Magnet	10 oz.
Voice coil	0.98 in (25 mm)
Woofers	Electroplate IMPP cone
Midrange and Tweeter	1.2 in (30 mm) Mylar dome tweeter, and 2 × 0.59 in (15 mm) piezo tweeter
Impedance	4 ohms

## One-Year Limited Warranty

Insignia Products ("Insignia") warrants to you, the original purchaser of this new **NS-S6501** ("Product"), that the Product shall be free of defects in the original manufacture of the material or workmanship for a period of one (1) year from the date of your purchase of the Product ("Warranty Period"). This Product must be purchased from an authorized dealer of Insignia brand products and packaged with this warranty statement. This warranty does not cover refurbished Product. If you notify Insignia during the Warranty Period of a defect covered by this warranty that requires service, terms of this warranty apply.

### How long does the coverage last?

The Warranty Period lasts for 1 year (365 days) from the date you purchased the Product. The purchase date is printed on the receipt you received with the Product.

### What does this warranty cover?

During the Warranty Period, if the original manufacture of the material or workmanship of the Product is determined to be defective by an authorized Insignia repair center or store personnel, Insignia will (at its sole option): (1) repair the Product with new or rebuilt parts; or (2) replace the Product at no charge with new or rebuilt comparable products or parts. Products and parts replaced under this warranty become the property of Insignia and are not returned to you. If service of Products or parts are required after the Warranty Period expires, you must pay all labor and parts charges. This warranty lasts as long as you own your Insignia Product during the Warranty Period. Warranty coverage terminates if you sell or otherwise transfer the Product.

### How to obtain warranty service?

If you purchased the Product at a retail store location, take your original receipt and the Product to the store you purchased it from. Make sure that you place the Product in its original packaging or packaging that provides the same amount of protection as the original packaging. If you purchased the Product from an online web site, mail your original receipt and the Product to the address listed on the web site. Make sure that you put the Product in its original packaging or packaging that provides the same amount of protection as the original packaging.

To obtain in-home warranty service for a television with a screen 25 inches or larger, call 1-888-BESTBUY. Call agents will diagnose and correct the issue over the phone or will have an Insignia-approved repair person dispatched to your home.

### Where is the warranty valid?

This warranty is valid only to the original purchaser of the product in the United States, Canada, and Mexico.

### What does the warranty not cover?

This warranty does not cover:

- Customer instruction
- Installation
- Set up adjustments
- Cosmetic damage
- Damage due to acts of God, such as lightning strikes
- Accident
- Misuse
- Abuse
- Negligence
- Commercial use
- Modification of any part of the Product, including the antenna
- Plasma display panel damaged by static (non-moving) images applied for lengthy periods (burn-in).

This warranty also does not cover:

- Damage due to incorrect operation or maintenance
- Connection to an incorrect voltage supply
- Attempted repair by anyone other than a facility authorized by Insignia to service the Product

- Products sold as is or with all faults
- Consumables, such as fuses or batteries
- Products where the factory applied serial number has been altered or removed

REPAIR REPLACEMENT AS PROVIDED UNDER THIS WARRANTY IS YOUR EXCLUSIVE REMEDY. INSIGNIA SHALL NOT BE LIABLE FOR ANY INCIDENTAL OR CONSEQUENTIAL DAMAGES FOR THE BREACH OF ANY EXPRESS OR IMPLIED WARRANTY ON THIS PRODUCT, INCLUDING, BUT NOT LIMITED TO, LOST DATA, LOSS OF USE OF YOUR PRODUCT, LOST BUSINESS OR LOST PROFITS. INSIGNIA PRODUCTS MAKES NO OTHER EXPRESS WARRANTIES WITH RESPECT TO THE PRODUCT, ALL EXPRESS AND IMPLIED WARRANTIES FOR THE PRODUCT, INCLUDING, BUT NOT LIMITED TO, ANY IMPLIED WARRANTIES OF AND CONDITIONS OF MERCHANTABILITY AND FITNESS FOR A PARTICULAR PURPOSE, ARE LIMITED IN DURATION TO THE WARRANTY PERIOD SET FORTH ABOVE AND NO WARRANTIES, WHETHER EXPRESS OR IMPLIED, WILL APPLY AFTER THE WARRANTY PERIOD. SOME STATES, PROVINCES AND JURISDICTIONS DO NOT ALLOW LIMITATIONS ON HOW LONG AN IMPLIED WARRANTY LASTS, SO THE ABOVE LIMITATION MAY NOT APPLY TO YOU. THIS WARRANTY GIVES YOU SPECIFIC LEGAL RIGHTS, AND YOU MAY ALSO HAVE OTHER RIGHTS, WHICH VARY FROM STATE TO STATE OR PROVINCE TO PROVINCE.

Contact Insignia:

For customer service please call 1-877-467-4289  
www.insignia-products.com

Distributed by Best Buy Purchasing, LLC  
7601 Penn Avenue South, Richfield, Minnesota, U.S.A.  
55423-3645

© 2008 Best Buy Enterprise Services, Inc.  
All rights reserved. INSIGNIA is a trademark of Best Buy Enterprise Services, Inc. Registered in some countries.  
All other products and brand names are trademarks of their respective owners.







[www.insignia-products.com](http://www.insignia-products.com) (877) 467-4289

Distributed by Best Buy Purchasing, LLC  
7601 Penn Avenue South, Richfield, MN USA 55423-3645  
© 2008 Best Buy Enterprise Services, Inc.

All rights reserved. INSIGNIA is a trademark of Best Buy Enterprise Services, Inc. Registered in some countries.  
All other products and brand names are trademarks of their respective owners.

ENGLISH  
08-1589